

## Bus-Polarity Correcting RS-485 Transceiver With IEC-ESD Protection

### FEATURES

- Exceeds Requirements of EIA-485 Standard
- Bus-Polarity Correction within 76 ms ( $t_{FS}$ )
- Data Rate: 300 bps to 250 kbps
- Works with Two Configurations:
  - Failsafe Resistors Only
  - Failsafe and Differential Termination Resistors
- Up to 256 Nodes on a Bus (1/8 unit load)
- SOIC-8 Package for Backward Compatibility
- Bus-Pin Protection:
  - $\pm 16$  kV HBM protection
  - $\pm 12$  kV IEC61000-4-2 Contact Discharge
  - +4 kV IEC61000-4-4 Fast Transient Burst

### APPLICATIONS

- E-Metering Networks
- Industrial Automation
- HVAC Systems
- DMX512-Networks
- Process Control
- Battery-Powered Applications

- Motion Control
- Telecom Equipment

### DESCRIPTION

The SN65HVD888 is a low-power RS-485 transceiver with automatic bus-polarity correction and transient protection. Upon hot plug-in, the device detects and corrects the bus polarity within the first 76 ms of bus idling. On-chip transient protection protects the device against IEC61000 ESD and EFT transients. This device has robust drivers and receivers for demanding industrial applications. The bus pins are robust to electrostatic discharge (ESD) events, with high levels of protection to Human-Body Model (HBM), Air-Gap Discharge, and Contact Discharge specifications.

The device combines a differential driver and a differential receiver, which operate together from a single 5-V power supply. The driver differential outputs and the receiver differential inputs are connected internally to form a bus port suitable for half-duplex (two-wire bus) communication. The device features a wide common-mode voltage range making the device suitable for multi-point applications over long cable runs. The SN65HVD888 is available in an SOIC-8 package, and is characterized from  $-40^{\circ}\text{C}$  to  $85^{\circ}\text{C}$ .

### TYPICAL NETWORK APPLICATION WITH POLARITY CORRECTION (POLCOR)

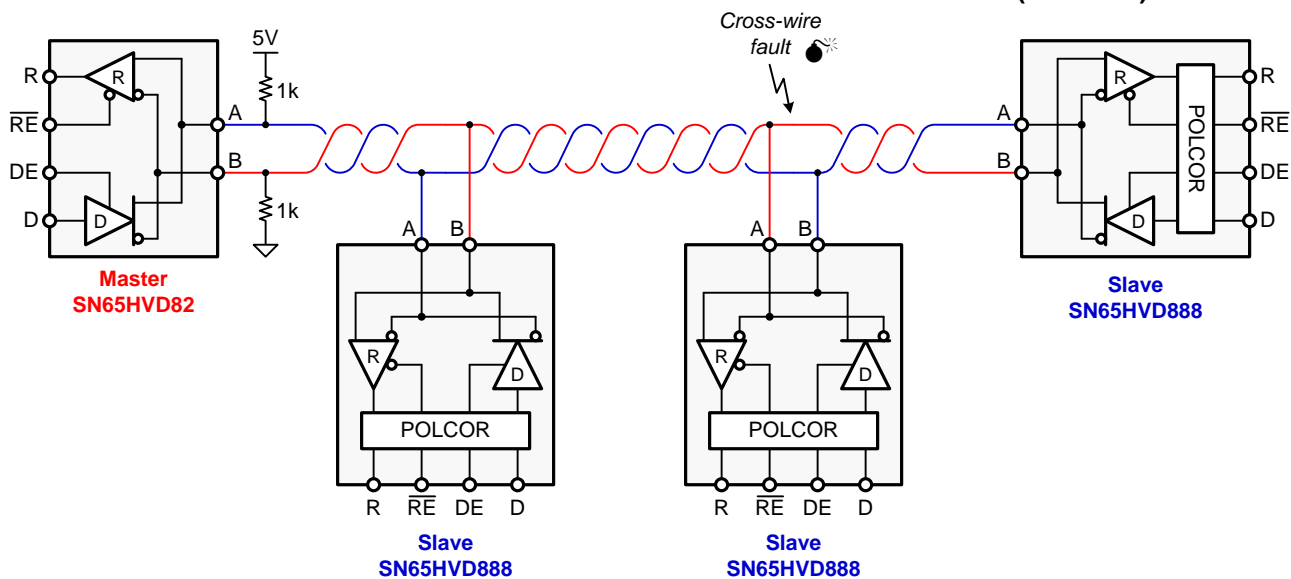

Please be aware that an important notice concerning availability, standard warranty, and use in critical applications of Texas Instruments semiconductor products and disclaimers thereto appears at the end of this data sheet.



These devices have limited built-in ESD protection. The leads should be shorted together or the device placed in conductive foam during storage or handling to prevent electrostatic damage to the MOS gates.

SOIC-8  
(TOP VIEW)

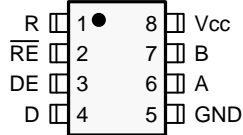

Block Diagram

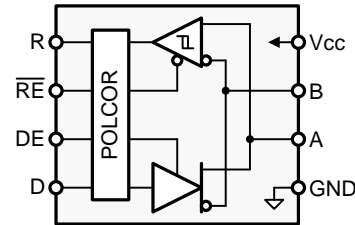

DRIVER PIN FUNCTIONS

INPUT	ENABLE	OUTPUTS		DESCRIPTION
D	DE	A	B	
<b>NORMAL MODE</b>				
H	H	H	L	Actively drives bus High
L	H	L	H	Actively drives bus Low
X	L	Z	Z	Driver disabled
X	OPEN	Z	Z	Driver disabled by default
OPEN	H	H	L	Actively drives bus High
<b>POLARITY-CORRECTING MODE<sup>(1)</sup></b>				
H	H	L	H	Actively drives bus Low
L	H	H	L	Actively drives bus High
X	L	Z	Z	Driver disabled
X	OPEN	Z	Z	Driver disabled by default
OPEN	H	L	H	Actively drives bus Low

(1) The polarity-correcting mode is entered when  $V_{ID} < V_{IT-}$  and  $t > t_{FS}$  and  $DE = low$ . This state is latched when  $/RE$  turns from Low to High.

RECEIVER PIN FUNCTIONS

DIFFERENTIAL INPUT	ENABLE	OUTPUT	DESCRIPTION
$V_{ID} = V_A - V_B$	$/RE$	R	
<b>NORMAL MODE</b>			
$V_{IT+} < V_{ID}$	L	H	Receive valid bus High
$V_{IT-} < V_{ID} < V_{IT+}$	L	?	Indeterminate bus state
$V_{ID} < V_{IT-}$	L	L	Receive valid bus Low
X	H	Z	Receiver disabled
X	OPEN	Z	Receiver disabled
Open, short, idle Bus	L	?	Indeterminate bus state
<b>POLARITY-CORRECTING MODE<sup>(1)</sup></b>			
$V_{IT+} < V_{ID}$	L	L	Receive valid bus Low
$V_{IT-} < V_{ID} < V_{IT+}$	L	?	Indeterminate bus state
$V_{ID} < V_{IT-}$	L	H	Receive polarity corrected bus High
X	H	Z	Receiver disabled
X	OPEN	Z	Receiver disabled
Open, short, idle Bus	L	?	Indeterminate bus state

(1) The polarity-correcting mode is entered when  $V_{ID} < V_{IT-}$  and  $t > t_{FS}$  and  $DE = low$ . This state is latched when  $/RE$  turns from Low to High.

**ABSOLUTE MAXIMUM RATINGS<sup>(1)</sup>**

		VALUE		UNIT
		MIN	MAX	
V <sub>CC</sub>	Supply voltage	-0.5	7	V
	Input voltage range at any logic pin	-0.3	5.7	
	Voltage input range, transient pulse, A and B, through 100 Ω	-100	100	
	Voltage range at A or B inputs	-18	18	
	Receiver output current	-24	24	mA
	Continuous total-power dissipation	See <a href="#">THERMAL INFORMATION</a> table		
	IEC 61000-4-2 ESD (Contact Discharge), bus terminals and GND		±12	kV
	IEC 61000-4-4 EFT (Fast transient or burst) bus terminals and GND		±4	
	IEC 60749-26 ESD (HBM), bus terminals and GND		±16	
JEDEC Standard 22	Test Method A114 (HBM), all pins		±4	V
	Test Method C101 (Charged Device Model), all pins		±1.5	
	Test Method A115 (Machine Model), all pins		±100	
T <sub>J</sub>	Junction temperature		170	°C
T <sub>STG</sub>	Storage temperature	-65	150	

- (1) Stresses beyond those listed under *absolute maximum ratings* may cause permanent damage to the device. These are stress ratings only and functional operation of the device at these or any other conditions beyond those indicated under *recommended operating conditions* is not implied. Exposure to absolute-maximum-rated conditions for extended periods may affect device reliability.

**THERMAL INFORMATION**

THERMAL METRIC <sup>(1)</sup>		SN65HVD888	UNITS
		PACKAGE SOIC (D)	
θ <sub>JA</sub>	Junction-to-ambient thermal resistance	116.1	°C/W
θ <sub>JCtop</sub>	Junction-to-case (top) thermal resistance	60.8	
θ <sub>JB</sub>	Junction-to-board thermal resistance <sup>(2)</sup>	57.1	
ψ <sub>JT</sub>	Junction-to-top characterization parameter	13.9	
ψ <sub>JB</sub>	Junction-to-board characterization parameter	56.5	
θ <sub>JCbot</sub>	Junction-to-case (bottom) thermal resistance	NA	

- (1) For more information about traditional and new thermal metrics, see the *IC Package Thermal Metrics* application report, [SPRA953](#).  
 (2) The junction-to-board thermal resistance is obtained by simulating in an environment with a ring cold plate fixture to control the PCB temperature, as described in JESD51-8.

**POWER DISSIPATION**

PARAMETER		TEST CONDITIONS	VALUE	UNITS	
PD	Power Dissipation driver and receiver enabled, V <sub>CC</sub> = 5.5 V, T <sub>J</sub> = 150°C 50% duty cycle square-wave signal at 250 kbps signaling rate:	Unterminated	R <sub>L</sub> = 300 Ω, C <sub>L</sub> = 50 pF (driver)	164	mW
		RS-422 load	R <sub>L</sub> = 100 Ω, C <sub>L</sub> = 50 pF (driver)	247	mW
		RS-485 load	R <sub>L</sub> = 54 Ω, C <sub>L</sub> = 50 pF (driver),	316	mW

## RECOMMENDED OPERATING CONDITIONS

		MIN	NOM	MAX	UNIT
$V_{CC}$	Supply voltage	4.5	5	5.5	V
$V_{ID}$	Differential input voltage	-12		12	
$V_I$	Input voltage at any bus terminal (separate or common mode) <sup>(1)</sup>	-7		12	
$V_{IH}$	High-level input voltage (driver, driver-enable, and receiver-enable inputs)	2		$V_{CC}$	
$V_{IL}$	Low-level input voltage (driver, driver-enable, and receiver-enable inputs)	0		0.8	
$I_O$	Output current	Driver		60	mA
		Receiver		8	
$C_L$	Differential load capacitance		50		pF
$R_L$	Differential load resistance		60		$\Omega$
$1/t_{UI}$	Signaling rate	0.3		250	kbps
$T_J$	Junction temperature	-40		150	°C
$T_A^{(2)}$	Operating free-air temperature (see <a href="#">THERMAL INFORMATION</a> for additional information)	-40		85	

- (1) The algebraic convention in which the least positive (most negative) limit is designated as minimum is used in this data sheet.  
 (2) Operation is specified for internal (junction) temperatures up to 150°C. Self-heating due to internal power dissipation should be considered for each application. Maximum junction temperature is internally limited by the thermal shut-down (TSD) circuit which disables the driver outputs when the junction temperature reaches 170°C.

## ELECTRICAL CHARACTERISTICS

over operating free-air temperature range (unless otherwise noted)

PARAMETER	TEST CONDITIONS		MIN	TYP	MAX	UNIT	
$ V_{OD} $	Driver differential-output voltage magnitude	RL = 60 $\Omega$ , 375 $\Omega$ on each output from -7 to +12 V	See <a href="#">Figure 1</a>	1.5	2.5	V	
		RL = 54 $\Omega$ (RS-485)	See <a href="#">Figure 2</a>	1.5	2.5		
		RL = 100 $\Omega$ (RS-422)		2	3		
$\Delta V_{OD} $	Change in magnitude of driver differential-output voltage	RL = 54 $\Omega$ , CL = 50 pF	See <a href="#">Figure 2</a>	-0.2	0	0.2	V
$V_{OC(SS)}$	Steady-state common-mode output voltage	Center of two 27- $\Omega$ load resistors	See <a href="#">Figure 2</a>	1	$V_{CC}/2$	3	V
$\Delta V_{OC}$	Change in differential driver common-mode output voltage			-0.2	0	0.2	mV
$V_{OC(PP)}$	Peak-to-peak driver common-mode output voltage			850			
$C_{OD}$	Differential output capacitance			8		pF	
$V_{IT+}$	Positive-going receiver differential-input voltage threshold			35	100	mV	
$V_{IT-}$	Negative-going receiver differential-input voltage threshold			-100	-35	mV	
$V_{HYS}^{(1)}$	Receiver differential-input voltage threshold hysteresis ( $V_{IT+} - V_{IT-}$ )			40	60	mV	
$V_{OH}$	Receiver high-level output voltage	$I_{OH} = -8$ mA		2.4	$V_{CC} - 0.3$	V	
$V_{OL}$	Receiver low-level output voltage	$I_{OL} = 8$ mA			0.2	0.4	V
$I_I$	Driver input, driver enable, and receiver enable input current			-2		2	$\mu$ A

- (1) Under any specific conditions,  $V_{IT+}$  is ensured to be at least  $V_{HYS}$  higher than  $V_{IT-}$ .

**ELECTRICAL CHARACTERISTICS (continued)**

over operating free-air temperature range (unless otherwise noted)

PARAMETER		TEST CONDITIONS		MIN	TYP	MAX	UNIT
$I_{OZ}$	Receiver high-impedance output current	VO = 0 V or VCC, /RE at VCC		-10		10	μA
$ I_{OS} $	Driver short-circuit output current	$ I_{OS} $ with $V_A$ or $V_B$ from -7 to +12 V				150	mA
$I_I$	Bus input current (driver disabled)	$V_{CC} = 4.5$ to $5.5$ V or	$V_I = 12$ V		75	125	μA
		$V_{CC} = 0$ V, DE at 0 V	$V_I = -7$ V	-100	-40		
$I_{CC}$	Supply current (quiescent)	Driver and receiver enabled	DE = V <sub>CC</sub> , /RE = GND, No load		750	900	μA
		Driver enabled, receiver disabled	DE = V <sub>CC</sub> , /RE = V <sub>CC</sub> , No load			650	
		Driver disabled, receiver enabled	DE = GND, /RE = GND, No load			750	
		Driver and receiver disabled	DE = GND, D = GND /RE = V <sub>CC</sub> , No load		0.4	5	
Supply current (dynamic)		See					

**SWITCHING CHARACTERISTICS**

3.3 ms &gt; bit time &gt; 4 μs (unless otherwise noted)

PARAMETER		TEST CONDITIONS		MIN	TYP	MAX	UNIT
<b>DRIVER</b>							
$t_r, t_f$	Driver differential-output rise and fall times	RL = 54 Ω, CL = 50 pF	See <a href="#">Figure 3</a>	400	700	1200	ns
$t_{PHL}, t_{PLH}$	Driver propagation delay			90	700	1000	
$t_{SK(P)}$	Driver pulse skew, $ t_{PHL} - t_{PLH} $				25	200	
$t_{PHZ}, t_{PLZ}$	Driver disable time		See <a href="#">Figure 4</a> and <a href="#">Figure 5</a>		50	500	ns
$t_{PHZ}, t_{PLZ}$	Driver enable time	Receiver enabled		500	1000		
		Receiver disabled		3	9	μs	
<b>RECEIVER</b>							
$t_r, t_f$	Receiver output rise and fall times	CL = 15 pF	See <a href="#">Figure 6</a>		18	30	ns
$t_{PHL}, t_{PLH}$	Receiver propagation delay time			85	195		
$t_{SK(P)}$	Receiver pulse skew, $ t_{PHL} - t_{PLH} $			1	15		
$t_{PHZ}, t_{PLZ}$	Receiver disable time			50	500		
$t_{PZL(1)}, t_{PZH(1)}, t_{PZL(2)}, t_{PZH(2)}$	Receiver enable time	Driver enabled	See <a href="#">Figure 7</a>	20	130	ns	
		Driver disabled	See <a href="#">Figure 8</a>	2	8	μs	
$t_{FS}$	Bus failsafe time	Driver disabled	See <a href="#">Figure 9</a>	44	58	76	ms

PARAMETER MEASUREMENT INFORMATION

DRIVER

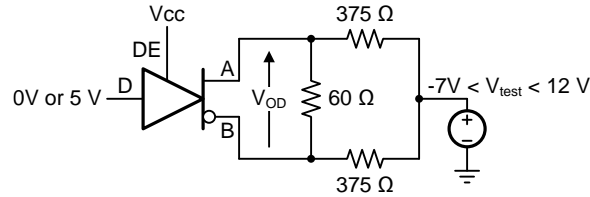

Figure 1. Measurement of Driver Differential-Output Voltage With Common-Mode Load

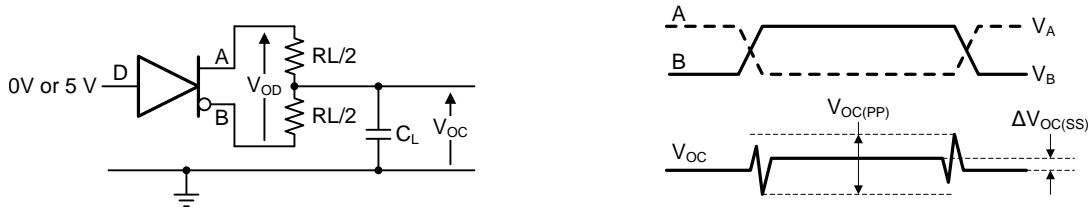

Figure 2. Measurement of Driver Differential and Common-Mode Output With RS-485 Load

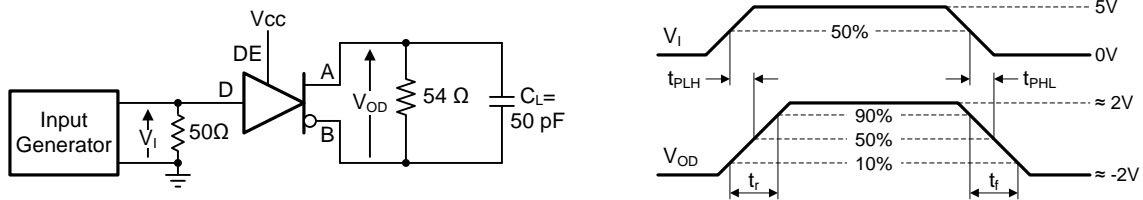

Figure 3. Measurement of Driver Differential-Output Rise and Fall Times and Propagation Delays

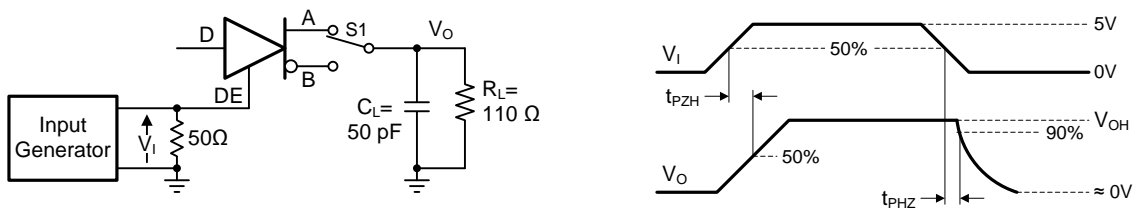

Figure 4. Measurement of Driver Enable and Disable Times With Active-High Output and Pull-Down Load

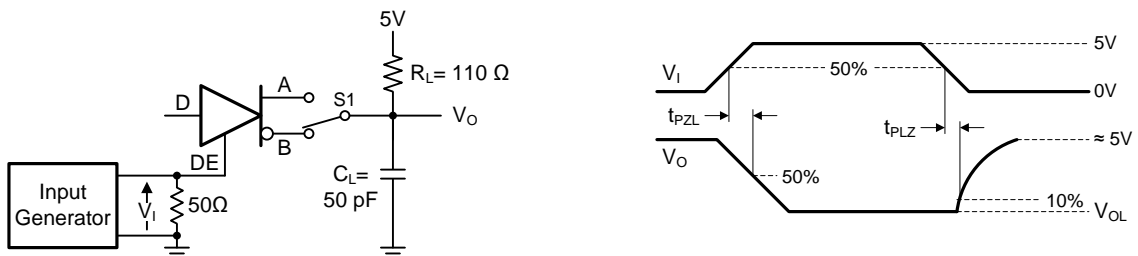

Figure 5. Measurement of Driver Enable and Disable Times With Active-Low Output and Pull-up Load

PARAMETER MEASUREMENT INFORMATION (continued)

RECEIVER

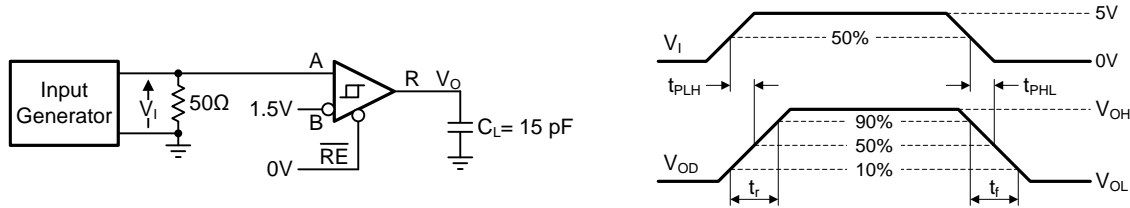

Figure 6. Measurement of Receiver Output Rise and Fall Times and Propagation Delays

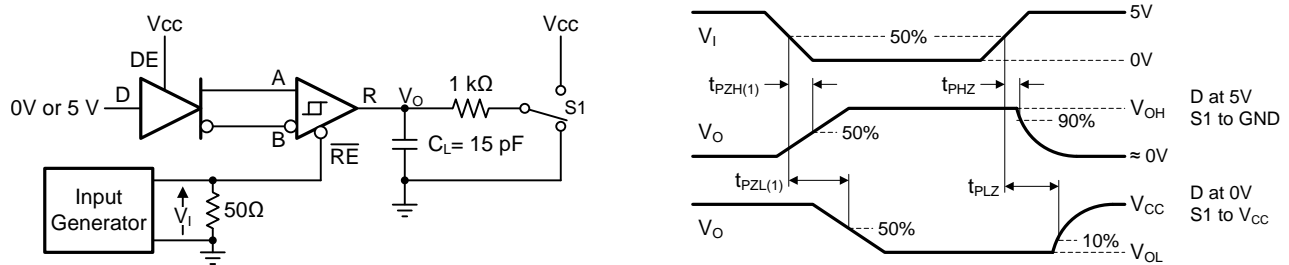

Figure 7. Measurement of Receiver Enable and Disable Times With Driver Enabled

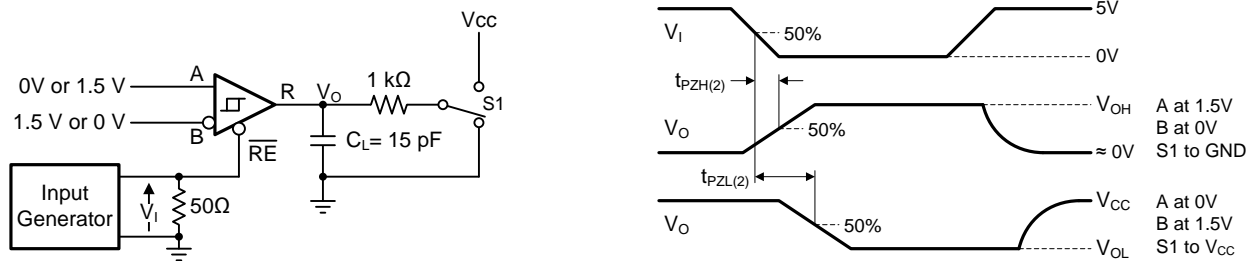

Figure 8. Measurement of Receiver Enable Times With Driver Disabled

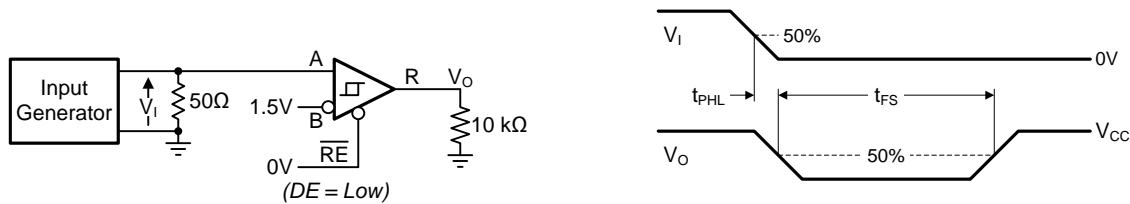
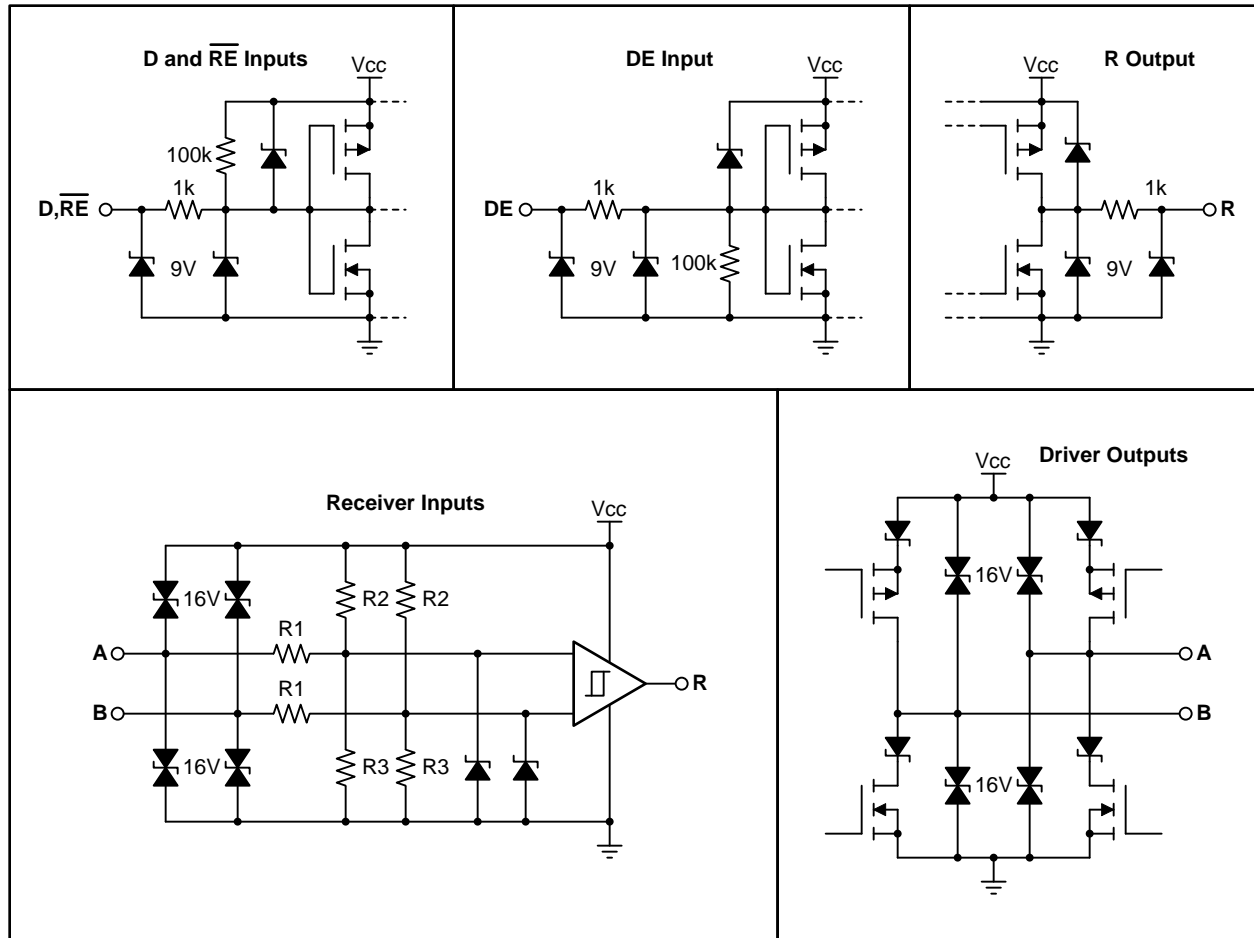

Figure 9. Measurement of Receiver Polarity-Correction Time With Driver Disabled

**EQUIVALENT INPUT AND OUTPUT SCHEMATIC DIAGRAMS**



**Figure 10. Equivalent Input and Output Schematic Diagrams**

## DEVICE INFORMATION

### Low-Power Standby Mode

When the driver and the receiver are both disabled (DE = Low and RE = High) the device enters standby mode. If the enable inputs are in the disabled state for only a brief time (for example: less than 100 ns), the device does not enter standby mode, preventing the SN65HVD888 from entering standby mode during driver or receiver enabling. Only when the enable inputs are held in the disabled state for a duration of 300 ns or more does the device enter low-power standby mode. In this mode most internal circuitry is powered down, and the steady-state supply current is typically less than 400 nA. When either the driver or the receiver is re-enabled, the internal circuitry becomes active. During  $V_{CC}$  power-up, when the device is set for both driver and receiver disabled mode, the device may consume more than 5- $\mu$ A of  $I_{CC}$  disabled current because of capacitance charging effects. This condition occurs only during  $V_{CC}$  power up.

### Bus Polarity Correction

The SN65HVD888 automatically corrects a wrong bus-signal polarity caused by a cross-wire fault. In order to detect the bus polarity, all three of the following conditions must be met:

- A failsafe-biasing network (commonly at the master node) must define the signal polarity of the bus
- A slave node must enable the receiver and disable the driver ( $\overline{RE} = DE = \text{Low}$ )
- The bus must idle for the failsafe time,  $t_{FS-max}$

After the failsafe time has passed, the polarity correction is complete and is applied to both the receive and transmit channels. The status of the bus polarity is latched within the transceiver and is maintained for subsequent data transmissions.

#### NOTE

Data string durations of consecutive 0s or 1s exceeding  $t_{FS-min}$  can accidentally trigger a wrong polarity correction and must be avoided.

Figure 11 shows a simple point-to-point data link between a master node and a slave node. Because the master node with the failsafe biasing network determines the signal polarity on the bus, an RS-485 transceiver without polarity correction, such as SN65HVD82, suffices. All other bus nodes, typically performing as slaves, require the SN65HVD888 transceiver with polarity correction.

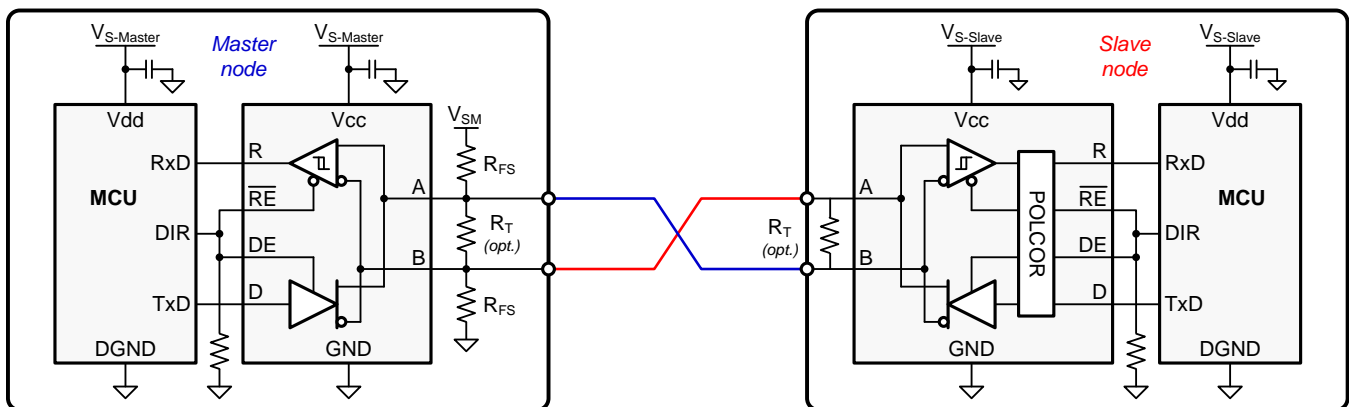
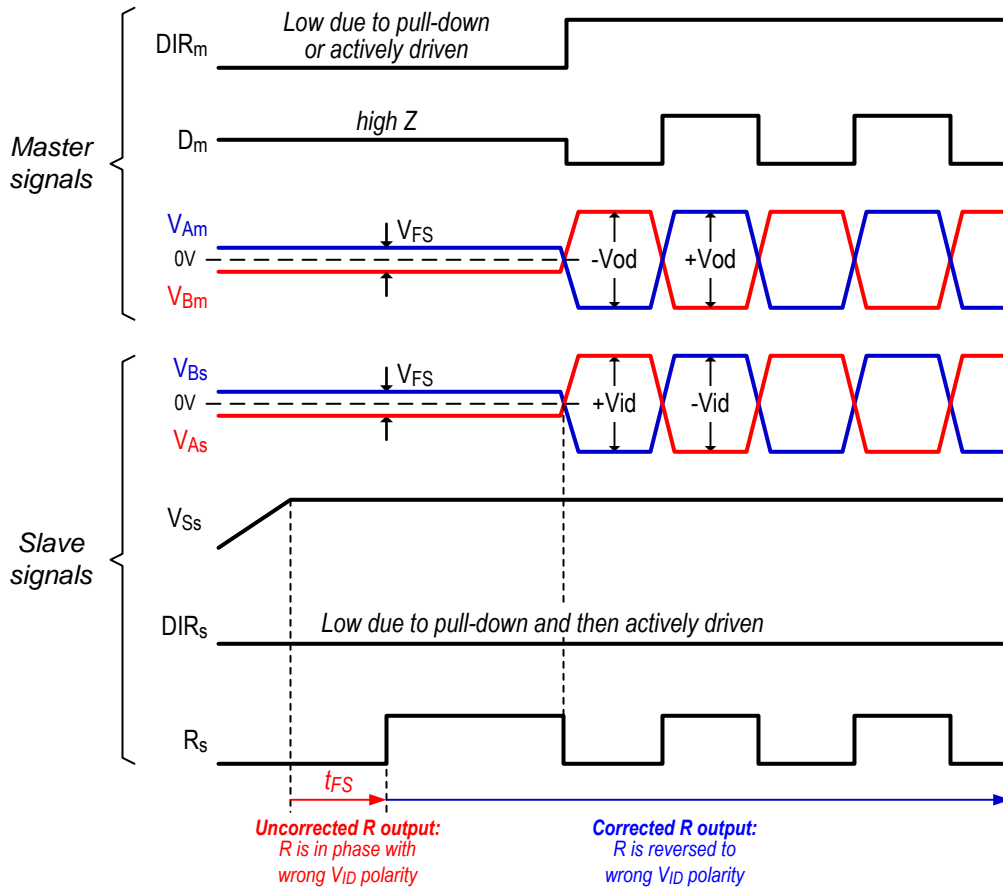

Figure 11. Point-To-Point Data Link With Cross-Wire Fault

Prior to initiating data transmission the master transceiver must idle for a time span that exceeds the maximum failsafe time,  $t_{FS-max}$ , of a slave transceiver. This idle time is accomplished by driving the direction control line, DIR, low. After a time,  $t > t_{FS-max}$ , the master begins transmitting data.

Because of the indicated cross-wire fault between master and slave, the slave node receives bus signals with reversed polarity. Assuming the slave node has just been connected to the bus, the direction-control pin is pulled-down during power-up and then is actively driven low by the slave MCU. The polarity correction begins as soon as the slave supply is established and ends after approximately 44 to 76 ms.



**Figure 12. Polarity Correction Timing Prior to a Data Transmission**

Initially the slave receiver assumes that the correct bus polarity is applied to the inputs and performs no polarity reversal. Because of the reversed polarity of the bus-failsafe voltage, the output of the slave receiver,  $R_S$ , turns low. After  $t_{FS}$  has passed and the receiver has detected the wrong bus polarity, the internal POLCOR logic reverses the input signal and  $R_S$  turns high.

At this point all incoming bus data with reversed polarity are polarity corrected within the transceiver. Because polarity correction is also applied to the transmit path, the data sent by the slave MCU are reversed by the POLCOR logic and then fed into the driver.

The reversed data from the slave MCU are reversed again by the cross-wire fault in the bus, and the correct bus polarity is reestablished at the master end.

This process repeats each time the device powers up and detects an incorrect bus polarity.

## APPLICATION INFORMATION

### Device Configuration

The SN65HVD888 is a half-duplex RS-485 transceiver operating from a single 5-V  $\pm 10\%$  supply. The driver and receiver enable pins allow for the configuration of different operating modes.

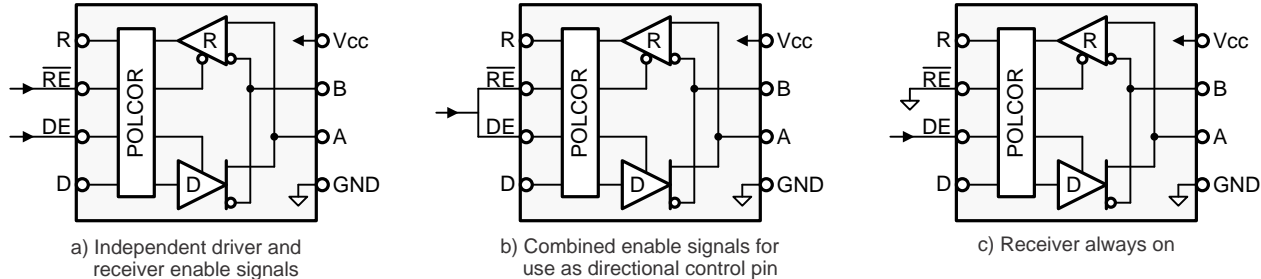

Figure 13. Transceiver Configurations

Using independent enable lines provides the most flexible control as the lines allow for the driver and the receiver to be turned on and turned off individually. While this configuration requires two control lines, it allows for selective listening to the bus traffic, whether the driver is transmitting data or not. Only this configuration allows the SN65HVD888 to enter low-power standby mode because it allows both the driver and receiver to be disabled simultaneously.

Combining the enable signals simplifies the interface to the controller by forming a single direction-control signal. Thus, when the direction-control line is high, the transceiver is configured as a driver, while for a low the device operates as a receiver.

Tying the receiver enable to ground and controlling only the driver-enable input also uses only one control line. In this configuration a node not only receives the data on the bus sent by other nodes but also receives the data sent on the bus, enabling the node to verify the correct data has been transmitted.

### Bus Design

An RS-485 bus consists of multiple transceivers connected in parallel to a bus cable. To eliminate line reflections, each cable end is terminated with a termination resistor,  $R_T$ , whose value matches the characteristic impedance,  $Z_0$ , of the cable. This method, known as parallel termination, allows for relatively high data rates over long cable length.

Common cables used are unshielded twisted pair (UTP), such as low-cost CAT-5 cable with  $Z_0 = 100 \Omega$ , and RS-485 cable with  $Z_0 = 120 \Omega$ . Typical cable sizes are AWG 22 and AWG 24.

The maximum bus length is typically given as 4000 ft or 1200 m, and represents the length of an AWG 24 cable whose cable resistance approaches the value of the termination resistance, thus reducing the bus signal by half or 6 dB. Actual maximum usable cable length depends on the signaling rate, cable characteristics, and environmental conditions.

Table 1. VID with a Failsafe Network and Bus Termination

$V_{CC}$	$R_L$ Differential Termination	$R_{FS}$ Pull up	$R_{FS}$ Pull down	$V_{ID}$
5 V	54 $\Omega$	560 $\Omega$	560 $\Omega$	230 mV
		1 K $\Omega$	1 K $\Omega$	131 mV
		4.7 K $\Omega$	4.7 K $\Omega$	29 mV
		10 K $\Omega$	10 K $\Omega$	13 mV

An external failsafe-resistor network must be used to ensure failsafe operation during an idle bus state. When the bus is not actively driven, the differential receiver inputs could float allowing the receiver output to assume a random output. A proper failsafe network forces the receiver inputs to exceed the VIT threshold, thus forcing the SN65HVD888 receiver output into the failsafe (high) state. Table 1 shows the differential input voltage ( $V_{ID}$ ) for various failsafe networks with a 54- $\Omega$  differential bus termination.

## Cable Length Versus Data Rate

There is an inverse relationship between data rate and cable length, which means the higher the data rate, the shorter the cable length; and conversely, the lower the data rate the longer the cable length. While most RS-485 systems use data rates between 10 kbps and 100 kbps, applications such as e-metering often operate at rates of up to 250 kbps even at distances of 4000 ft and longer. Longer distances are possible by allowing for small signal jitter of up to 5 or 10%.

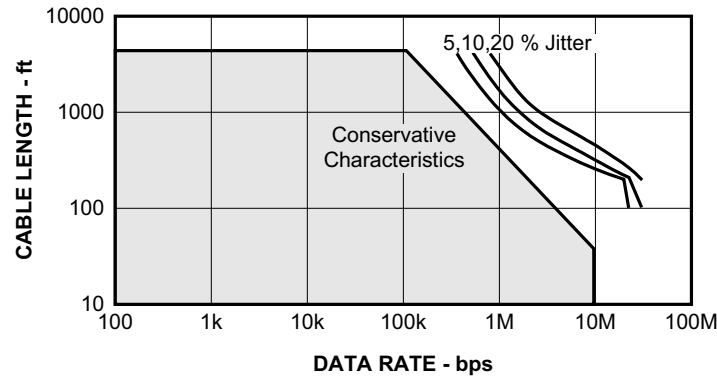

Figure 14. Cable Length vs Data Rate Characteristic

## Stub Length

When connecting a node to the bus, the distance between the transceiver inputs and the cable trunk, known as the stub, should be as short as possible. The reason for the short distance is because a stub presents a non-terminated piece of bus line which can introduce reflections if the distance is too long. As a general guideline, the electrical length or round-trip delay of a stub should be less than one-tenth of the rise time of the driver, thus leading to a maximum physical stub length of as shown in Equation 1.

$$L_{\text{Stub}} \leq 0.1 \times t_r \times v \times c$$

where

- $t_r$  is the 10/90 rise time of the driver
  - $c$  is the speed of light ( $3 \times 10^8$  m/s or  $9.8 \times 10^8$  ft/s)
  - $v$  is the signal velocity of the cable ( $v = 78\%$ ) or trace ( $v = 45\%$ ) as a factor of  $c$
- (1)

Based on Equation 1, with a minimum rise time of 400 ns, Equation 2 shows the maximum cable-stub length of the SN65HVD888.

$$L_{\text{Stub}} \leq 0.1 \times 400 \times 10^{-9} \times 3 \times 10^8 \times 0.78 = 9.4 \text{ m (or 30.6 ft)}$$
(2)

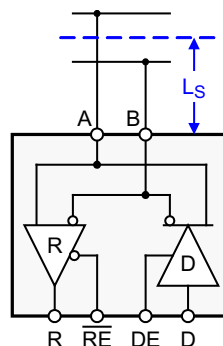

Figure 15. Stub Length

### 3- to 5-V Interface

Interfacing the SN65HVD888 to a 3-V controller is easy. Because the 5-V logic inputs of the transceiver accept 3-V input signals they can be directly connected to the controller I/O. The 5-V receiver output, R, however must be level-shifted by a Schottky diode and a 10-k resistor to connect to the controller input (see Figure 16). When R is high, the diode is reverse biased and the controller supply potential lies at the controller RxD input. When R is low, the diode is forward biased and conducts. In this case only the diode forward voltage of 0.2 V lies at the controller RxD input.

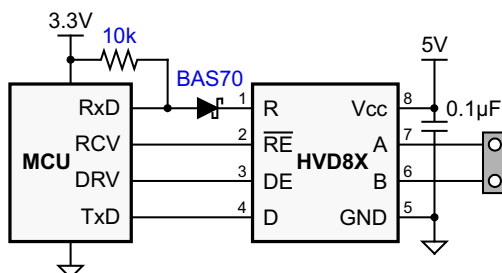

Figure 16. 3-V to 5-V Interface

### Noise Immunity

The input sensitivity of a standard RS-485 transceiver is  $\pm 200$  mV. When the differential input voltage,  $V_{ID}$ , is greater than +200 mV, the receiver output turns high, for  $V_{ID} < -200$  mV the receiver outputs low.

The SN65HVD888 transceiver implements high receiver noise-immunity by providing a typical positive-going input threshold of 35 mV and a minimum hysteresis of 40 mV. In the case of a noisy input condition therefore, a differential noise voltage of up to 40 mV<sub>PP</sub> can be present without causing the receiver output to change states from high to low.

### Transient Protection

The bus terminals of the SN65HVD888 transceiver family possess on-chip ESD protection against  $\pm 16$  kV HBM and  $\pm 12$  kV IEC61000-4-2 contact discharge. The International Electrotechnical Commission (IEC) ESD test is far more severe than the HBM ESD test. The 50% higher charge capacitance,  $C_S$ , and 78% lower discharge resistance,  $R_D$  of the IEC model produce significantly higher discharge currents than the HBM model.

As stated in the IEC 61000-4-2 standard, contact discharge is the preferred transient protection test method. Although IEC air-gap testing is less repeatable than contact testing, air discharge protection levels are inferred from the contact discharge test results.

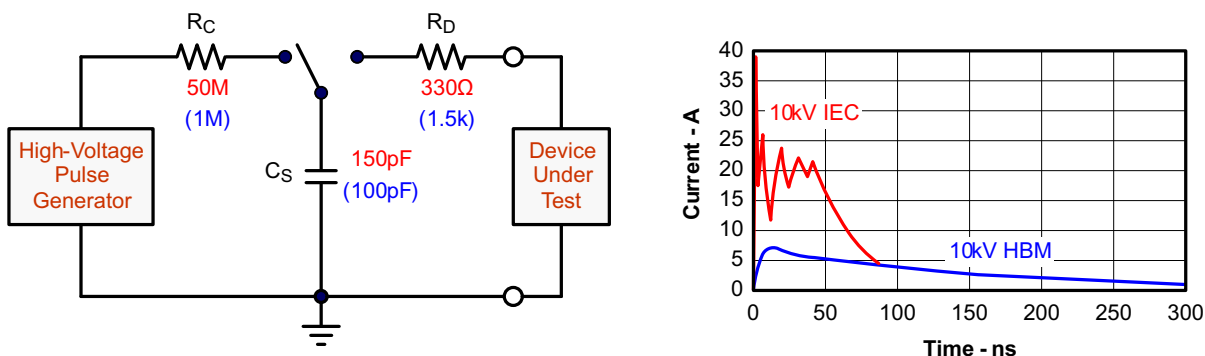

Figure 17. HBM and IEC-ESD Models and Currents in Comparison (HBM Values in Parenthesis)

The on-chip implementation of IEC ESD protection significantly increases the robustness of equipment. Common discharge events occur because of human contact with connectors and cables. Designers may choose to implement protection against longer duration transients, typically referred to as surge transients. [Figure 9](#) suggests two circuit designs providing protection against short and long duration surge transients, in addition to ESD and Electrical Fast Transients (EFT) transients. [Table 2](#) lists the bill of materials for the external protection devices.

EFTs are generally caused by relay-contact bounce or the interruption of inductive loads. Surge transients often result from lightning strikes (direct strike or an indirect strike which induce voltages and currents), or the switching of power systems, including load changes and short circuits switching. These transients are often encountered in industrial environments, such as factory automation and power-grid systems.

[Figure 18](#) compares the pulse-power of the EFT and surge transients with the power caused by an IEC ESD transient. In the diagram on the left of [Figure 18](#), the tiny blue blip in the bottom left corner represents the power of a 10-kV ESD transient, which already dwarfs against the significantly higher EFT power spike, and certainly dwarfs against the 500-V surge transient. This type of transient power is well representative of factory environments in industrial and process automation. The diagram on the right of [Figure 18](#) compares the enormous power of a 6-kV surge transient, most likely occurring in e-metering applications of power generating and power grid systems, with the aforementioned 500-V surge transient.

#### NOTE

The unit of the pulse-power changes from kW to MW, thus making the power of the 500-V surge transient almost dropping off the scale.

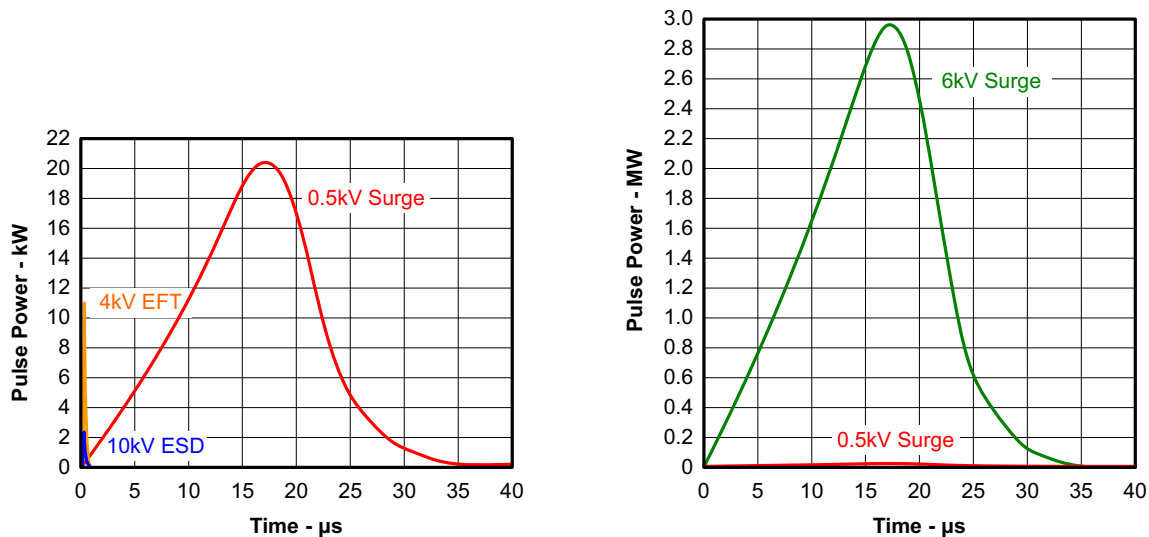

**Figure 18. Power Comparison of ESD, EFT, and Surge Transients**

In the case of surge transients, high-energy content is signified by long pulse duration and slow decaying pulse power

The electrical energy of a transient that is dumped into the internal protection cells of the transceiver is converted into thermal energy. This thermal energy heats the protection cells and literally destroys them, thus destroying the transceiver. [Figure 19](#) shows the large differences in transient energies for single ESD, EFT, and surge transients as well as for an EFT pulse train, commonly applied during compliance testing.

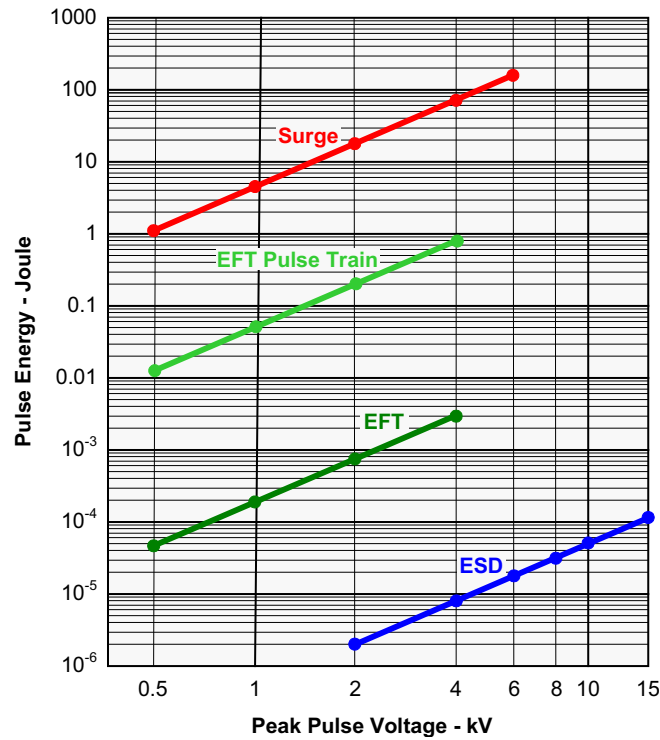

Figure 19. Comparison of Transient Energies

Table 2. Bill of Materials

Device	Function	Order Number	Manufacturer
XCVR	5-V, 250-kbps RS-485 Transceiver	SN65HVD888	TI
R1, R2	10-Ω, Pulse-Proof Thick-Film Resistor	CRCW0603010RJNEAHP	Vishay
TVS	Bidirectional 400-W Transient Suppressor	CDSOT23-SM712	Bourns
TBU1, TBU2	Bidirectional.	TBU-CA-065-200-WH	Bourns
MOV1, MOV2	200mA Transient Blocking Unit 200-V, Metal-Oxide Varistor	MOV-10D201K	Bourns

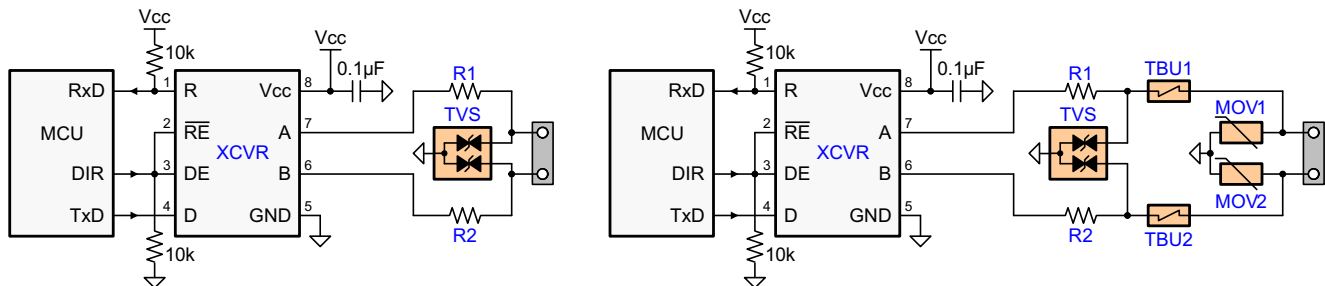

Figure 20. Transient Protections Against ESD, EFT, and Surge Transients

The left circuit shown in Figure 20 provides surge protection of  $\geq 500$ -V transients, while the right protection circuits can withstand surge transients of 5 kV.

## Design and Layout Considerations For Transient Protection

Because ESD and EFT transients have a wide frequency bandwidth from approximately 3 MHz to 3 GHz, high-frequency layout techniques must be applied during PCB design.

In order for PCB design to be successful, begin with the design of the protection circuit in mind.

1. Place the protection circuitry close to the bus connector to prevent noise transients from penetrating your board.
2. Use  $V_{CC}$  and ground planes to provide low-inductance. Note that high-frequency currents follow the path of least inductance and not the path of least impedance.
3. Design the protection components into the direction of the signal path. Do not force the transients currents to divert from the signal path to reach the protection device.
4. Apply 100- to 220-nF bypass capacitors as close as possible to the  $V_{CC}$ -pins of transceiver, UART, controller ICs on the board.
5. Use at least two vias for  $V_{CC}$  and ground connections of bypass capacitors and protection devices to minimize effective via-inductance.
6. Use 1- to 10-k pullup or pulldown resistors for enable lines to limit noise currents in these lines during transient events.
7. Insert pulse-proof resistors into the A and B bus lines if the TVS clamping voltage is higher than the specified maximum voltage of the transceiver bus terminals. These resistors limit the residual clamping current into the transceiver and prevent it from latching up.
  - While pure TVS protection is sufficient for surge transients up to 1 kV, higher transients require metal-oxide varistors (MOVs) which reduce the transients to a few-hundred volts of clamping voltage, and transient blocking units (TBUs) that limit transient current to some 200 mA.

## Isolated Bus Node Design

Many RS-485 networks use isolated bus nodes to prevent the creation of unintended ground loops and their disruptive impact on signal integrity. An isolated bus node typically includes a micro controller that connects to the bus transceiver through a multi-channel, digital isolator (Figure 21).

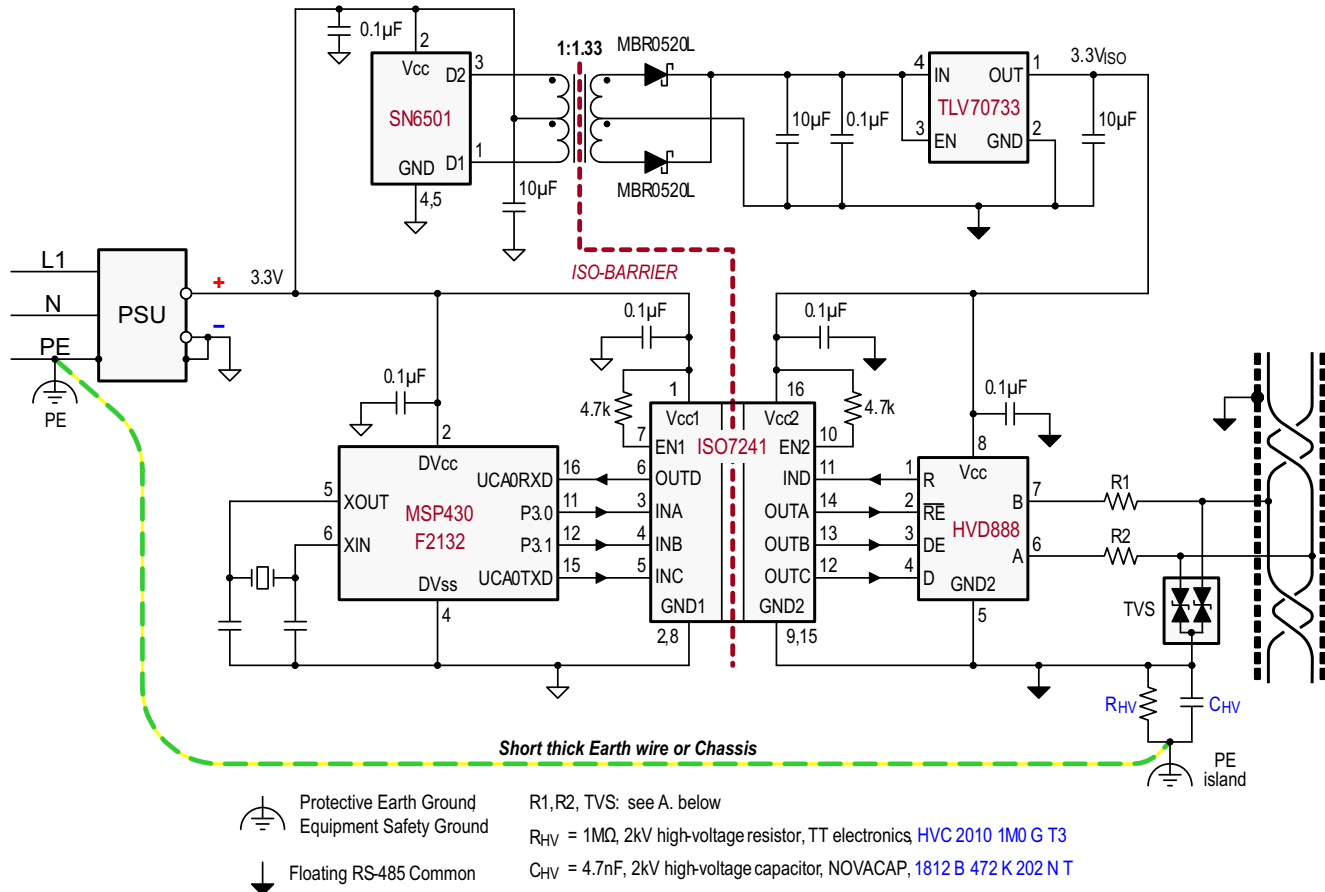

A. See Table 2.

Figure 21. Isolated Bus Node With Transient Protection

Power isolation is accomplished using the push-pull transformer driver SN6501 and a low-cost LDO, TLV70733.

Signal isolation uses the quadruple digital isolator ISO7241. Notice that both enable inputs, EN1 and EN2, are pulled-up via 4.7-k resistors to limit input currents during transient events.

While the transient protection is similar to the one in Figure 20 (left circuit), an additional high-voltage capacitor diverts transient energy from the floating RS-485 common further towards Protective Earth (PE) ground. This diversion is necessary as noise transients on the bus are usually referred to Earth potential.

R<sub>VH</sub> refers to a high-voltage resistor, and in some applications even a varistor. This resistance is applied to prevent charging of the floating ground to dangerous potentials during normal operation.

Occasionally varistors are used instead of resistors in order to rapidly discharge C<sub>HV</sub>, if expected that fast transients might charge C<sub>HV</sub> to high-potentials.

Note that the PE island represents a copper island on the PCB for the provision of a short, thick Earth wire connecting this island to PE ground at the entrance of the power supply unit (PSU).

In equipment designs using a chassis, the PE connection is usually provided through the chassis itself. Typically the PE conductor is tied to the chassis at one end while the high-voltage components, C<sub>HV</sub> and R<sub>HV</sub>, are connecting to the chassis at the other end.

**PACKAGING INFORMATION**

Orderable Device	Status (1)	Package Type	Package Drawing	Pins	Package Qty	Eco Plan (2)	Lead/Ball Finish	MSL Peak Temp (3)	Op Temp (°C)	Device Marking (4/5)	Samples
SN65HVD888D	PREVIEW	SOIC	D	8	75	Green (RoHS & no Sb/Br)	CU NIPDAU	Level-1-260C-UNLIM	-40 to 85	HVD888	
SN65HVD888DR	PREVIEW	SOIC	D	8	2500	Green (RoHS & no Sb/Br)	CU NIPDAU	Level-1-260C-UNLIM	-40 to 85	HVD888	

(1) The marketing status values are defined as follows:

**ACTIVE:** Product device recommended for new designs.

**LIFEBUY:** TI has announced that the device will be discontinued, and a lifetime-buy period is in effect.

**NRND:** Not recommended for new designs. Device is in production to support existing customers, but TI does not recommend using this part in a new design.

**PREVIEW:** Device has been announced but is not in production. Samples may or may not be available.

**OBsolete:** TI has discontinued the production of the device.

(2) Eco Plan - The planned eco-friendly classification: Pb-Free (RoHS), Pb-Free (RoHS Exempt), or Green (RoHS & no Sb/Br) - please check <http://www.ti.com/productcontent> for the latest availability information and additional product content details.

**TBD:** The Pb-Free/Green conversion plan has not been defined.

**Pb-Free (RoHS):** TI's terms "Lead-Free" or "Pb-Free" mean semiconductor products that are compatible with the current RoHS requirements for all 6 substances, including the requirement that lead not exceed 0.1% by weight in homogeneous materials. Where designed to be soldered at high temperatures, TI Pb-Free products are suitable for use in specified lead-free processes.

**Pb-Free (RoHS Exempt):** This component has a RoHS exemption for either 1) lead-based flip-chip solder bumps used between the die and package, or 2) lead-based die adhesive used between the die and leadframe. The component is otherwise considered Pb-Free (RoHS compatible) as defined above.

**Green (RoHS & no Sb/Br):** TI defines "Green" to mean Pb-Free (RoHS compatible), and free of Bromine (Br) and Antimony (Sb) based flame retardants (Br or Sb do not exceed 0.1% by weight in homogeneous material)

(3) MSL, Peak Temp. -- The Moisture Sensitivity Level rating according to the JEDEC industry standard classifications, and peak solder temperature.

(4) There may be additional marking, which relates to the logo, the lot trace code information, or the environmental category on the device.

(5) Multiple Device Markings will be inside parentheses. Only one Device Marking contained in parentheses and separated by a "~" will appear on a device. If a line is indented then it is a continuation of the previous line and the two combined represent the entire Device Marking for that device.

**Important Information and Disclaimer:** The information provided on this page represents TI's knowledge and belief as of the date that it is provided. TI bases its knowledge and belief on information provided by third parties, and makes no representation or warranty as to the accuracy of such information. Efforts are underway to better integrate information from third parties. TI has taken and continues to take reasonable steps to provide representative and accurate information but may not have conducted destructive testing or chemical analysis on incoming materials and chemicals. TI and TI suppliers consider certain information to be proprietary, and thus CAS numbers and other limited information may not be available for release.

In no event shall TI's liability arising out of such information exceed the total purchase price of the TI part(s) at issue in this document sold by TI to Customer on an annual basis.

D (R-PDSO-G8)

PLASTIC SMALL OUTLINE

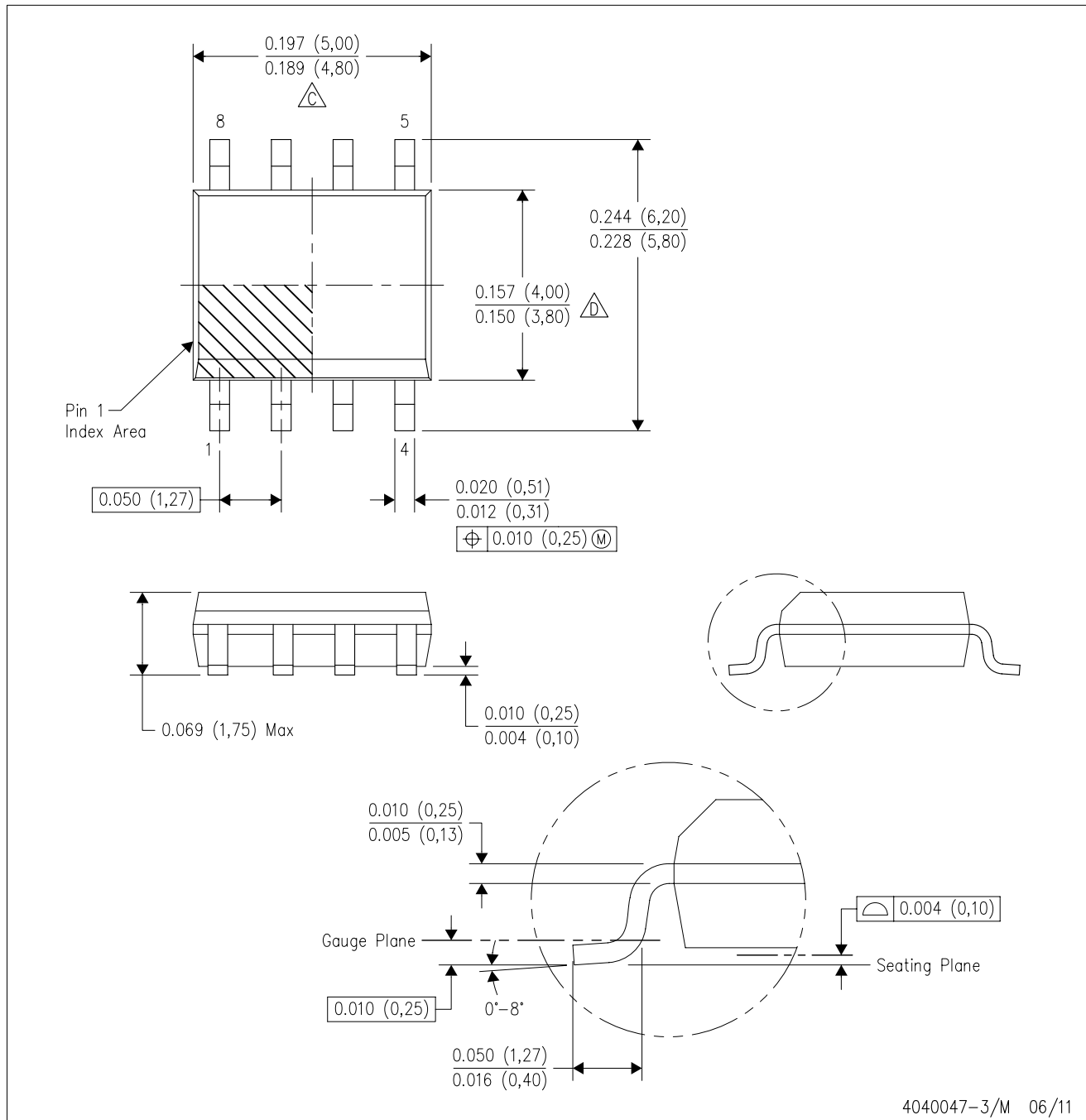

- NOTES:
- A. All linear dimensions are in inches (millimeters).
  - B. This drawing is subject to change without notice.
  - C. Body length does not include mold flash, protrusions, or gate burrs. Mold flash, protrusions, or gate burrs shall not exceed 0.006 (0,15) each side.
  - D. Body width does not include interlead flash. Interlead flash shall not exceed 0.017 (0,43) each side.
  - E. Reference JEDEC MS-012 variation AA.

D (R-PDSO-G8)

PLASTIC SMALL OUTLINE

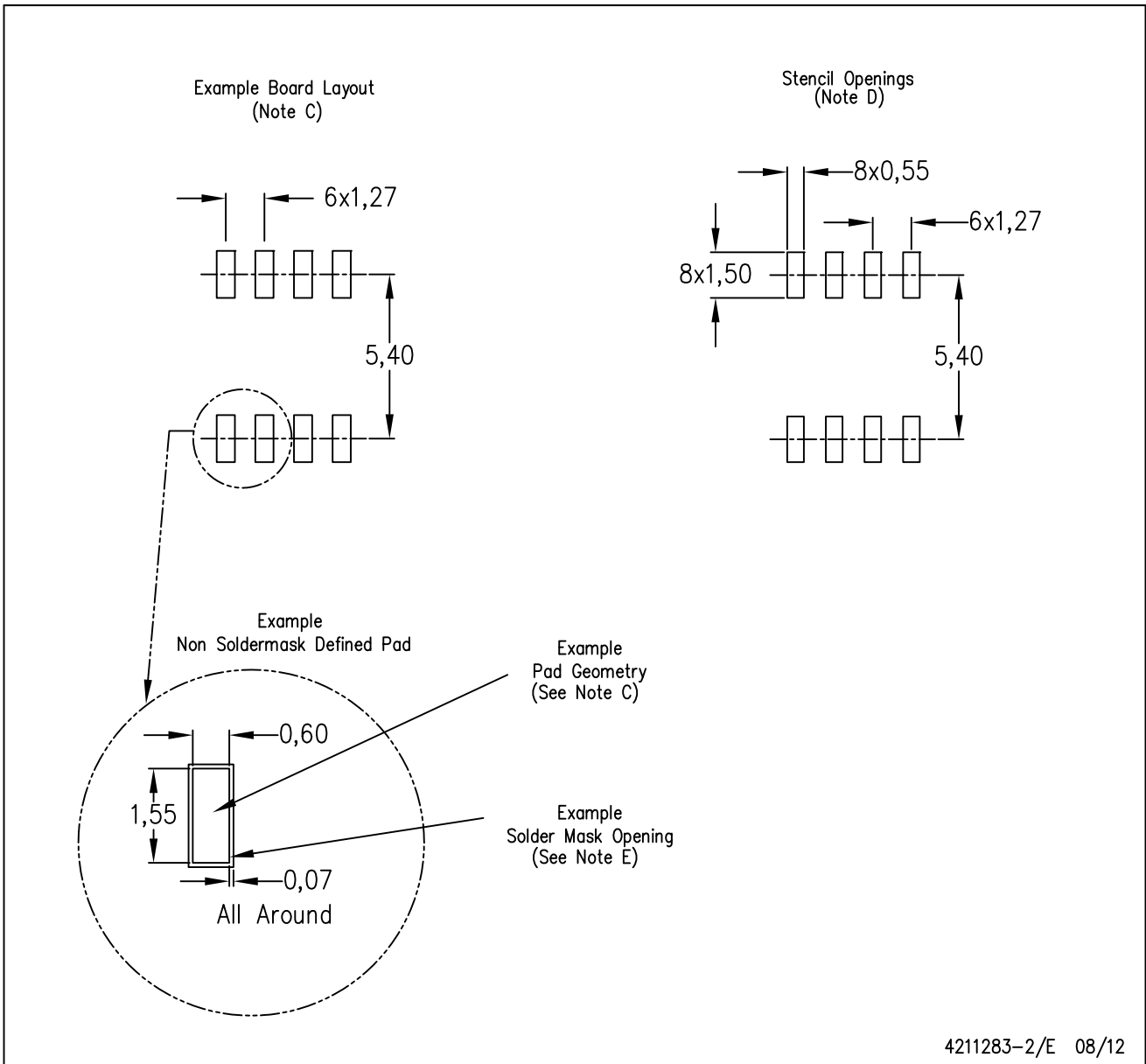

4211283-2/E 08/12

- NOTES:
- A. All linear dimensions are in millimeters.
  - B. This drawing is subject to change without notice.
  - C. Publication IPC-7351 is recommended for alternate designs.
  - D. Laser cutting apertures with trapezoidal walls and also rounding corners will offer better paste release. Customers should contact their board assembly site for stencil design recommendations. Refer to IPC-7525 for other stencil recommendations.
  - E. Customers should contact their board fabrication site for solder mask tolerances between and around signal pads.

## IMPORTANT NOTICE

Texas Instruments Incorporated and its subsidiaries (TI) reserve the right to make corrections, enhancements, improvements and other changes to its semiconductor products and services per JESD46, latest issue, and to discontinue any product or service per JESD48, latest issue. Buyers should obtain the latest relevant information before placing orders and should verify that such information is current and complete. All semiconductor products (also referred to herein as "components") are sold subject to TI's terms and conditions of sale supplied at the time of order acknowledgment.

TI warrants performance of its components to the specifications applicable at the time of sale, in accordance with the warranty in TI's terms and conditions of sale of semiconductor products. Testing and other quality control techniques are used to the extent TI deems necessary to support this warranty. Except where mandated by applicable law, testing of all parameters of each component is not necessarily performed.

TI assumes no liability for applications assistance or the design of Buyers' products. Buyers are responsible for their products and applications using TI components. To minimize the risks associated with Buyers' products and applications, Buyers should provide adequate design and operating safeguards.

TI does not warrant or represent that any license, either express or implied, is granted under any patent right, copyright, mask work right, or other intellectual property right relating to any combination, machine, or process in which TI components or services are used. Information published by TI regarding third-party products or services does not constitute a license to use such products or services or a warranty or endorsement thereof. Use of such information may require a license from a third party under the patents or other intellectual property of the third party, or a license from TI under the patents or other intellectual property of TI.

Reproduction of significant portions of TI information in TI data books or data sheets is permissible only if reproduction is without alteration and is accompanied by all associated warranties, conditions, limitations, and notices. TI is not responsible or liable for such altered documentation. Information of third parties may be subject to additional restrictions.

Resale of TI components or services with statements different from or beyond the parameters stated by TI for that component or service voids all express and any implied warranties for the associated TI component or service and is an unfair and deceptive business practice. TI is not responsible or liable for any such statements.

Buyer acknowledges and agrees that it is solely responsible for compliance with all legal, regulatory and safety-related requirements concerning its products, and any use of TI components in its applications, notwithstanding any applications-related information or support that may be provided by TI. Buyer represents and agrees that it has all the necessary expertise to create and implement safeguards which anticipate dangerous consequences of failures, monitor failures and their consequences, lessen the likelihood of failures that might cause harm and take appropriate remedial actions. Buyer will fully indemnify TI and its representatives against any damages arising out of the use of any TI components in safety-critical applications.

In some cases, TI components may be promoted specifically to facilitate safety-related applications. With such components, TI's goal is to help enable customers to design and create their own end-product solutions that meet applicable functional safety standards and requirements. Nonetheless, such components are subject to these terms.

No TI components are authorized for use in FDA Class III (or similar life-critical medical equipment) unless authorized officers of the parties have executed a special agreement specifically governing such use.

Only those TI components which TI has specifically designated as military grade or "enhanced plastic" are designed and intended for use in military/aerospace applications or environments. Buyer acknowledges and agrees that any military or aerospace use of TI components which have **not** been so designated is solely at the Buyer's risk, and that Buyer is solely responsible for compliance with all legal and regulatory requirements in connection with such use.

TI has specifically designated certain components as meeting ISO/TS16949 requirements, mainly for automotive use. In any case of use of non-designated products, TI will not be responsible for any failure to meet ISO/TS16949.

### Products

Audio	<a href="http://www.ti.com/audio">www.ti.com/audio</a>
Amplifiers	<a href="http://amplifier.ti.com">amplifier.ti.com</a>
Data Converters	<a href="http://dataconverter.ti.com">dataconverter.ti.com</a>
DLP® Products	<a href="http://www.dlp.com">www.dlp.com</a>
DSP	<a href="http://dsp.ti.com">dsp.ti.com</a>
Clocks and Timers	<a href="http://www.ti.com/clocks">www.ti.com/clocks</a>
Interface	<a href="http://interface.ti.com">interface.ti.com</a>
Logic	<a href="http://logic.ti.com">logic.ti.com</a>
Power Mgmt	<a href="http://power.ti.com">power.ti.com</a>
Microcontrollers	<a href="http://microcontroller.ti.com">microcontroller.ti.com</a>
RFID	<a href="http://www.ti-rfid.com">www.ti-rfid.com</a>
OMAP Applications Processors	<a href="http://www.ti.com/omap">www.ti.com/omap</a>
Wireless Connectivity	<a href="http://www.ti.com/wirelessconnectivity">www.ti.com/wirelessconnectivity</a>

### Applications

Automotive and Transportation	<a href="http://www.ti.com/automotive">www.ti.com/automotive</a>
Communications and Telecom	<a href="http://www.ti.com/communications">www.ti.com/communications</a>
Computers and Peripherals	<a href="http://www.ti.com/computers">www.ti.com/computers</a>
Consumer Electronics	<a href="http://www.ti.com/consumer-apps">www.ti.com/consumer-apps</a>
Energy and Lighting	<a href="http://www.ti.com/energy">www.ti.com/energy</a>
Industrial	<a href="http://www.ti.com/industrial">www.ti.com/industrial</a>
Medical	<a href="http://www.ti.com/medical">www.ti.com/medical</a>
Security	<a href="http://www.ti.com/security">www.ti.com/security</a>
Space, Avionics and Defense	<a href="http://www.ti.com/space-avionics-defense">www.ti.com/space-avionics-defense</a>
Video and Imaging	<a href="http://www.ti.com/video">www.ti.com/video</a>

### TI E2E Community

[e2e.ti.com](http://e2e.ti.com)